

*Crogioli qualità
ISOALUSTAR, STARRBIDE e GRAPHITE*

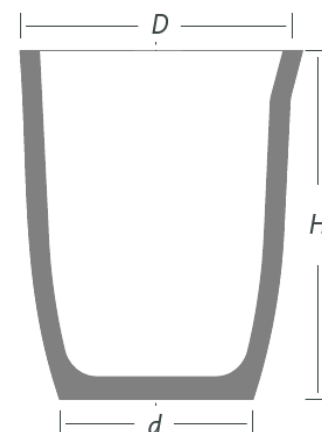

FORMA A

Forma	AG GRAPHITE		A ISOALUSTAR		AC STARRBIDE	
	H (mm)	D/d (mm)	H (mm)	D/d (mm)	H (mm)	D/d (mm)
6/0	29	25/19*				
5/0	35	32/25*				
4/0	51	41/27*				
3/0	54	48/32*				
2/0	57	52/36*				
1/0	72	60/42*				
1/2	80	74/50*				
3/4	90	80/50*				
1	90	90/55*			95	84/57
1 1/2	100	95/60*				
2	110	100/65*			115	105/70
3	130	110/70*				
4	140	115/75*			145	120/80
5	150	125/85*				
6	165	130/90*			165	140/95
7	175	140/95*				
8	180	155/110*			185	155/105
9	185	160/115*				
10	200	160/110*				
12	210	170/120*				
14	220	175/120*				
15	230	180/120*				
16	235	185/125*			230	200/130
18	240	193/130*			240	200/130
20	255	200/135*			255	200/130
25	260	220/150*			260	220/145*
30	290	230/160*	290	240/160	290	230/155*
35	300	240/170*			300	240/160*
40	310	260/190*			310	260/265*
50	330	270/200*			330	270/175*
60	345	285/200*			345	285/190*
70	360	295/205*			360	295/200*
80	375	305/215*			370	305/200*
90	380	315/225*			380	325/220*
100	400	325/235*	400	325/205	400	325/220*
120	410	345/245*				
130	420	350/245*				
150	450	370/260*	450	350/210	450	370/260*
175					470	370/260*
200	500	400/285	500	400/255	500	400/280
250	515	420/295	515	420/225	515	420/280
300	540	440/300	240	440/260	540	440/265
350	590	475/330	590	465/320	590	465/290
400	600	500/340	600	500/350	600	510/360
500	650	510/350	650	510/350	650	515/360
600	680	530/380	680	540/380	680	550/360
800	800	560/380	800	560/380	800	560/360
1000					820	650/420
1100					890	650/420



*con bocchello di colata

Le forme da A 200 a A 1100 sono prive di bocchello di colata

Forma BN

Forma	BN ISOALUSTAR					
	H (mm)	D/d (mm)	PT h(mm) B/b		PL h(mm) B/b	
150	490	525/230	300	13/11		
175	550	525/230	350	13/11		
200	600	525/230	400	13/11		
204	700	525/230	500	13/11		
210	500	610/245	250	13/11		
250	630	615/245	380	13/11		
300	700	615/245	450	13/11		
350	800	615/245	540	13/11		
360	900	615/245	640	13/11		
400	600	705/305			260*	10/7
410	700	705/305			360*	10/7
420	800	710/305			460*	10/7
430	940	715/305			600*	10/7
500	750	775/310	450	13/11		
600	900	780/310	600	13/11		
687	900	825/285	490	13/11		
690	1000	825/285	590	13/11		
750	880	875/350	460	10/7	460	10/7
800	1000	880/350	580	10/7	580	10/7
900	1100	880/350	680	10/7	680	10/7
1100	1170	885/350	750	10/7	750	10/7
1200	1250	885/350	830	10/7	830	10/7
1500	1500	885/350	1080	10/7	1080	10/7
1600	1505	830/285				

Le forme BN sono disponibili con tasca pirometrica (PT) o con foro parete (PL)

*disponibili solo con foro parete. Tolleranza del foro $\pm 1.5\text{mm}$

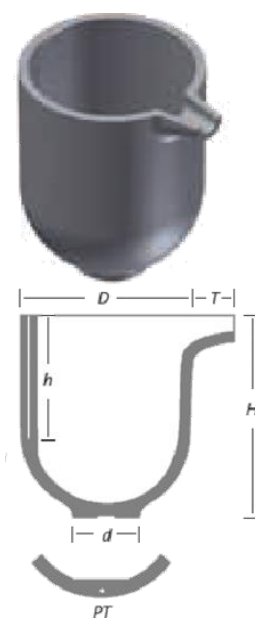
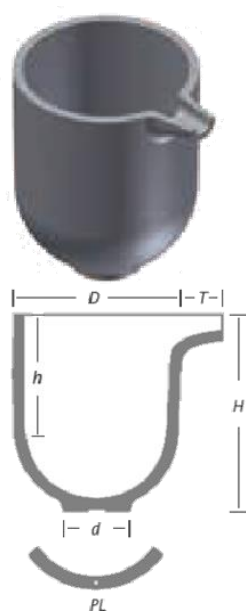
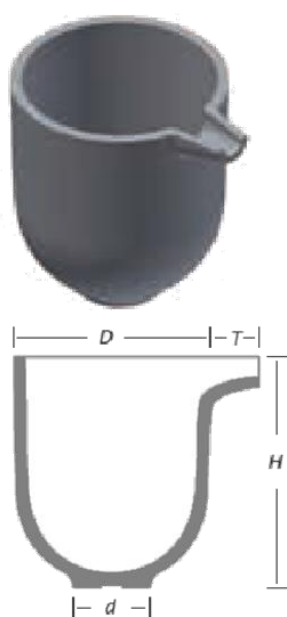

FORMA BU

Forma	BUG GRAPHITE		BU ISOALUSTAR				BUC STARRBIDE	
	H (mm)	D/d (mm)	H (mm)	D/d (mm)	PL h (mm) B/b	H (mm)	D/d (mm)	
35	345	400/215				345	400/205	
50	395	400/215				395	400/205	
60	430	400/215				430	400/205	
75	375	465/280				375	465/280	
100	400	525/305	400	515/305		400	525/305	
125	450	525/305	450	520/305		450	525/305	
150	490	525/305	490	520/305		490	525/305	
175	550	525/305	550	525/305		550	525/305	
200	600	525/305	600	525/305		600	530/310	
202						620	530/310	
203						650	530/310	
204						700	530/310	
206						760	530/310	
210	500	615/355		615/320		500	615/355	
250	630	615/355	530*	615/320		630	615/355	
300	700	615/355	700*	615/320		700	615/355	
350	800	615/355	800*	615/320		800	615/355	
360	900	615/355	900	615/320		900	615/355	
370			1050	615/320		1050	615/355	
MD 13			700	730/370				
500	750	775/435	750	775/360		750	765/370	
600	900	780/380	900*	780/350		900	765/360	
700			1000**	780/350		1000	780/400	
730			1400	850/350				
750	880	880/450						
800	1000	890/450						
910	1000	950/635						
1110			940**	965/335	480	10/7		
1210			1050**	970/335	590	10/7		
1310	1200	956/635	1200**	975/335	740	10/7		
1510			1320**	980/335	860	10/7		
1800			1600**	1050/540	860	10/7		

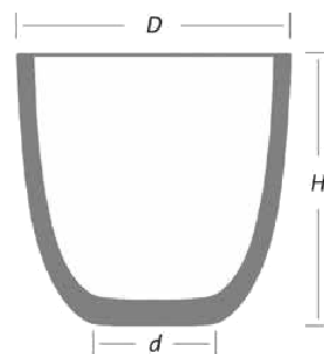

Per l'impiego su forni rovesciabili questi crogioli possono essere forniti con un recesso circolare nella base (VT) oppure con una asolatura (AE) per cementare un bocchello

Dimensioni standard asolatura: sino diam. 615 = 30 x 80 mm
da diam. 775 = 60 x 120 mm

*disponibile con tasca pirometrica

**disponibile con foro paretale

FORMA C

Forma	CG GRAPHITE		CC STARRBIDE ISOALUSTAR	
	H (mm)	D/d (mm)	H (mm)	D/d (mm)
20	280	200/145		
25	305	205/150		
30	320	225/165		
35	335	225/170		
40	340	240/180		
50	370	250/180	370	250/175
60	400	260/190	400	250/175
70	410	270/190	410	270/200
80	440	275/205	440	275/200
100	480	295/210	480	295/215
120	520	310/220	510	310/220
150	550	330/230	550	325/235
200	600	350/250	600	345/235*



Sino alla forma C80 non dispongono di recesso circolare nella base

* senza labbro di colata

FORMA FU

Forma	FU ISO-ALUSTAR		FUC STARRBIDE	
	H (mm)	D/d (mm)	H (mm)	D/d (mm)
107	635	330/215		
300			870	445/295
500	990	480/320	990	480/290
600			1090	480/290
750	1130	540/330	1130	540/330
1000	1130	650/380	1130	550/335
1200			1100	615/360
1500			1130	670/420
2000			1130	780/420
2500	1250	780/350	1235	780/420
3000	1400	790/350	1400	780/720

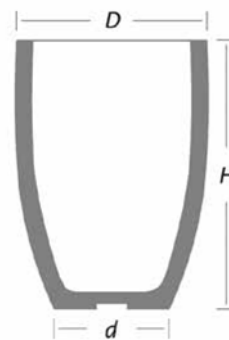

Asolatura (AE) sino diam. 615 è 40 x 80 mm

Recesso circolare (VT) = 12x100 mm

FORMA TP

Forma	TPG GRAPHITE			TPC STARRBIDE		
	H (mm)	D/d (mm)	T (mm)	H (mm)	D/d (mm)	T (mm)
254	430	260/490	150			
173	490	315/230	90	490	295/225	100
722	565	325/240	115			
246	470	355/265	120			
184	590	355/240	130			
400	615	360/240	120	615	345/245	135
723	640	380/280	120	640	370/270	120
843	675	420/255	150	675	420/295	150
196				780	370/270	120
600				805	370/270	120
982	800	435/295	150	800	430/295	150
274				720	430/295	150
12				940	430/295	150
16				970	540/360	150

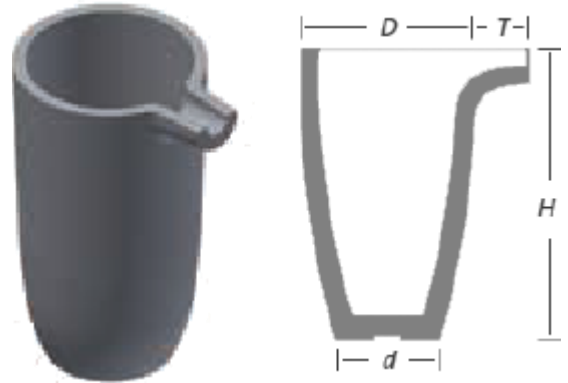

FORMA TP (FORMA BU CON BOCCELLO DI COLATA)

Forma	TPG GRAPHITE			TP ISO-ALUSTAR			TPC STARRBIDE		
	H (mm)	D/d (mm)	T (mm)	H (mm)	D/d (mm)	T (mm)	H (mm)	D/d (mm)	T (mm)
287				600	525/305	150	600	525/310	150
89	740	540/310	150				740	525/310	150
387				630	615/360		630	615/360	150
412				800	615/360		800	615/360	150
412/H				900	615/320		900	615/360	150
587				900	780/350		900	780/400	170
587 H							1000	780/400	170



FORMA P (FORMA TP SENZA BECCO DI COLATA)

Forma	PG GRAPHITE		P ISOALUSTAR		PC STARRBIDE	
	H (mm)	D/d (mm)	H (mm)	D/d (mm)	H (mm)	D/d (mm)
6	675	420/255			675	415/285
8			800	420/230	800	435/295
10	940	440/295			940	440/295
14			1015	435/235	1015	445/295
15	970	540/360	970	540/330	970	540/360
389					690	345/245
830			1190	540/330	1190	540/360
901	760	290/240			760	295/225
904	915	345/240			915	345/245
980			1220	680/360	1220	675/420
983			1800	710/360		

Recesso nella base (vt) H=12, diam=100mm

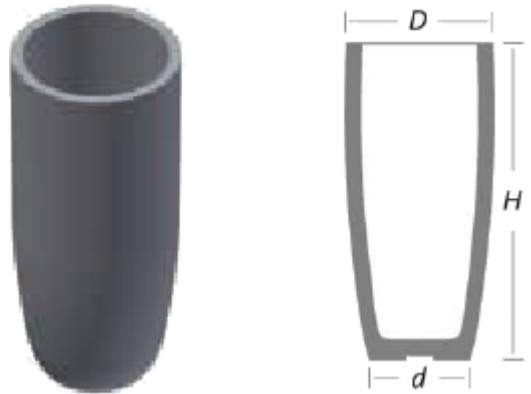

FORMA R

Forma	RG GRAPHITE		R ISOALUSTAR		RC STARRBIDE	
	H (mm)	D/d (mm)	H (mm)	D/d (mm)	H (mm)	D/d (mm)
200	620	350/250			620	345/240
250	650	370/270			650	370/270
300	750	445/280			720	430/270
350					750	430/290
500			840	480/320	840	480/290
600			940	480/320	940	480/290

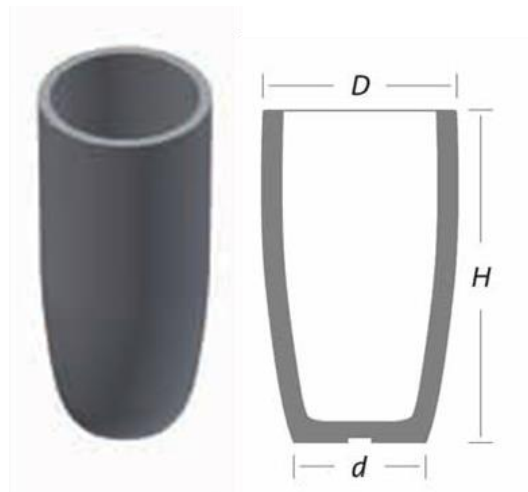

CROGIOLI PER FORNI ROVESCIBILI

FORMA TBN (FORMA BN CON BOCHELLO DI COLATA)

Forma	TBN ISOALUSTAR						T (mm)
	H (mm)	D/d (mm)	PT		PL		
			h (mm)	B/b	h(mm)	B/b	
287	600	525/230	400	13/11			170
387	630	615/245	380	13/11			170
387 H	765	615/245	445	13/11			170
412	800	615/245	550	13/11			170
412 H	900	615/245	650	13/11			170
587	900	780/310	600				170*
587 H	1000	780/300					170*
687	900	830/285	490	13/11			170
690	1000	830/285	560	13/11			170
750	880	875/350	460	10/7	460	10/7	200
800	1000	880/350**	580	10/7	580	10/7	200*
900	1100	880/350**	680	10/7	680	10/7	200*
1100	1170	880/350**	750	10/7	750	10/7	200*
1200	1250	880/350	830	10/7	830	10/7	200
1500	1500	880/350	1080	10/7	1080	10/7	200

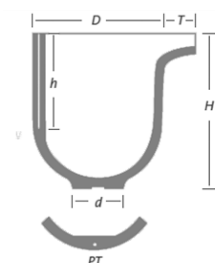
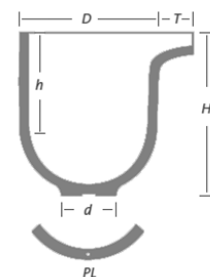
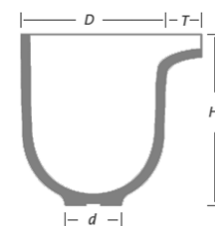

*La posizione standard della tasca (PT) o della foratura paretale (PL) è a 180°, pertanto opposta al bocchello

Tolleranza del foro: $\pm 1,5\text{mm}$

**Versione standard $d=330$

FORMA TPG SF1

Forma	TPG SF1 GRAPHITE				
	H (mm)	h (mm)	D (mm)	d (mm)	T (mm)
287	600	300	550	305	240
387	700	300	630	360	150
412	800	425	615	355	300
530	850	500	780	480	340
587	900	550	780	380	300

Crogioli per siviere di trasporto riscaldate – tipo 1

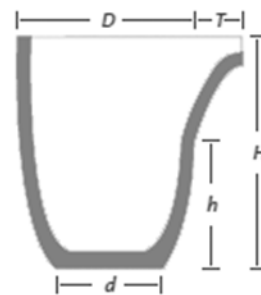

FORMA TPG SF2

Forma	TPG SF2 GRAPHITE				
	H (mm)	h (mm)	D (mm)	d (mm)	T (mm)
412	500	200	615	355	360
550	750	150	780	500	365
587	900	300	780	435	400
750	900	300	880	470	410

Crogioli per siviere di trasporto riscaldate – tipo 2

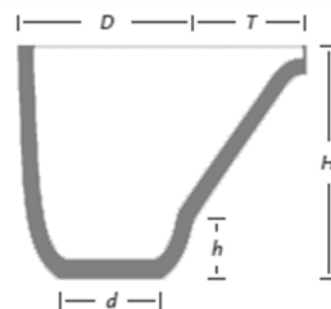

FORMA US BOWL (BACINELLA)

Forma	BC STARRBIDE		B ISO-ALUSTAR	
	H (mm)	D/d (mm)	H (mm)	D/d (mm)
300	470	570/305		
350	405	700/305		
400	445	700/305		
450	485	700/305		
500	525	715/305		
600	585	720/305		
700	560	860/380	560	860/330
800	605	870/380	605	870/330
900	650	880/380	650	880/330
1000	710	885/380	710	885/330

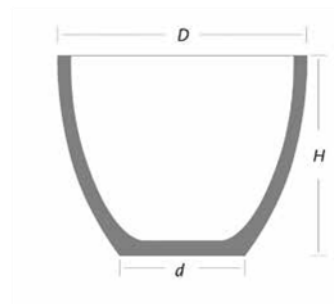
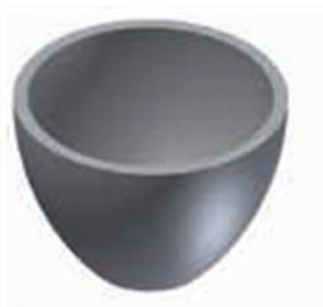

FORMA US INDUCTION (CON BASE AMPIA)

Forma	NOC STARRBIDE		
	H (mm)	D (mm)	d (mm)
1128	710	525	405
1130	760	525	405
1132	815	525	405
2130	760	605	480
2132	718	605	480
33100	935	710	535
33270	1050	710	535
33000 H MAX	1195	710	535

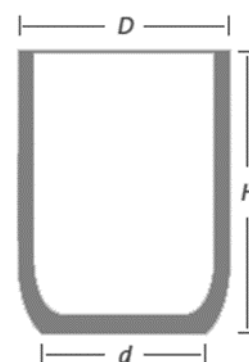

SIVIERE

FORME LADLE LINERS

Forma	LLG GRAPHITE		
	H (mm)	D (mm)	d (mm)
60	205	200	160
100	240	235	205
150	265	260	230
200	290	300	250
250	320	3058	265
300	330	330	285
350	355	330	285
400	370	355	310
500	395	395	350
600	425	405	350
1000	500	485	425
1500	560	545	465
2000	635	610	535
3000	710	655	595

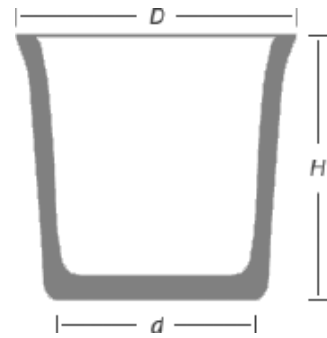

Disponibili anche con tubo sifone e piastra (BP)

FORME PER COLATA CONTINUA

Forma	CC ISO-ALUSTAR					
	A (mm)	B (mm)	C (mm)	D (mm)	E x F max (mm)	G x H (mm)
A	650	255	200	200	200x255	Su richiesta
A	1050	440	360	170	340x440	Su richiesta
B	1050	440	360	220	∅ 380	Su richiesta
A	1500	520	430	240	400x250	Su richiesta
B	1500	520	430	240	∅ 400	Su richiesta

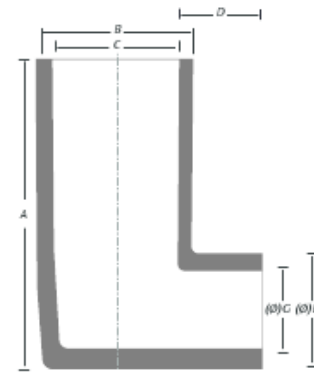

Altre particolare misure a richiesta



FORMA CILINDRICA

Forma	ZYL G GRAPHITE		ZYLC STARRBIDE	
	H _{max} * (mm)	D/d (mm)	H _{max} * (mm)	D/d (mm)
200x80	200	80/75		
170x100	170	100/100	170	100/100
205x115	205	115/110	205	115/110
250x135			250	135/130
290x145	290	145/145		
360x155	360	155/150		
390x165	390	165/160		
320x170			320	170/165
280x180	280	180/180		
400x190	400	190/185		
550x205	550	220/200		
355x220			355	220/215
470x220	470	220/25		
490x225	490	225/195		
405x230	405	230/220		
530x240	530	240/225		
600x250	600	250/245		
470x255			475	255/245
475x265			475	265/255
490x265	490	265/250		
720x295	720	295/285		
530x305	530	3005/300		
460x315	460	315/300		
480x310			480	310/305
700x330	700	330/320		
820x340	820	340/335		
510x360	510	360/350	510	360/350
630x385			630	385/380
730x385	730	385/380		
1000x405				
560x405	560	405/400		
650x415	650	415/405		
690x415			690	415/405
710x420	710	420/410		



FORMA CILINDRICA

Forma	ZYL G GRAPHITE		ZYL ISO-ALUSTAR		ZYLC STARRBIDE	
	H _{max} * (mm)	D/d (mm)	H _{max} * (mm)	D/d (mm)	H _{max} * (mm)	D/d (mm)
760x445					760	445/430
950x450	950	450/420				
1000x465			1000	465/440		
920x470	920	470/460				
1100x475			1100	475/475		
850x485					850	485/475
1000x485	1000	485/475				
1525x525			1525	525/500		
700x535	700	535/530				
950x550	950	550/535				
815x560	815	560/550				
905x560			905	560/540		
1000x585					1000	585/570
850x600	850	600/590				
1100x605			1100	605/600		
1090x615	1090	615/595				
970x640			970	640/615		
1000x730			1000	730/695		
830x740	830	740/715				
2025x775			2025	775/700		
1450x790					1450	790/785
2000x810			2000	810/800		
1850x880			1850	880/880		
1850x900			1850	900/900		
2025x950			2025	950/880		
1950x965			1950	965/960		
1300x980			1300	980/735		



SUPPORTI

Cod	Tipo	H (mm)	D (mm)														
			150	200	220	240	260	280	300	320	355	375	400	440	460	500	540
UCG	1&2	50	X	X	X	X	X	X	X	X	X	X	X	X	X	X	X
UCG	1&2	75	X	X	X	X	X	X	X	X	X	X	X	X	X	X	X
UCG	3&4	100	X	X	X	X	X	X	X	X	X	X	X	X	X	X	X
UCG	3&4	125	X	X	X	X	X	X	X	X	X	X	X	X	X	X	X
UCG	3&4	150	X	X	X	X	X	X	X	X	X	X	X	X	X	X	X
UCG	3&4	175	X	X	X	X	X	X	X	X	X	X	X	X	X	X	X
UC	3&4	200	X	X	X	X	X	X	X	X	X	X	X	X	X	X	X
UC	3&4	225		X	X	X	X	X	X	X	X	X	X	X	X	X	X
UC	3&4	250				X	X	X	X	X	X	X	X	X	X	X	X
UC	3&4	275				X	X	X	X	X	X	X	X	X	X	X	X
UC	3&4	300				X	X	X	X	X	X	X	X	X	X	X	X
UC	3&4	325					X	X	X	X	X	X	X	X	X		
UC	3&4	350					X	X	X	X	X	X	X	X	X		
UC	3&4	375								X	X	X	X	X	X		
UC	3&4	400								X	X	X	X	X	X		

Qualità **UCG**: grafite argilla

Qualità **UC**: carburo di silicio

Recesso standard nella base:

Sino a diam. 280=17/95mm

Sino a diam. 540=20/200mm

Cod	Tipo	H (mm)	D (mm)		
			600	650	700
UG	1	75	X	X	X
UG	1	100	X	X	X
Cod	Tipo	H (mm)	D (mm)	d (mm)	bx d2 (mm)
UC	5&6	200	320	250	17X95
UC	5&6	200	355	250	50X135
UC	5&6	215	375	300	50X160

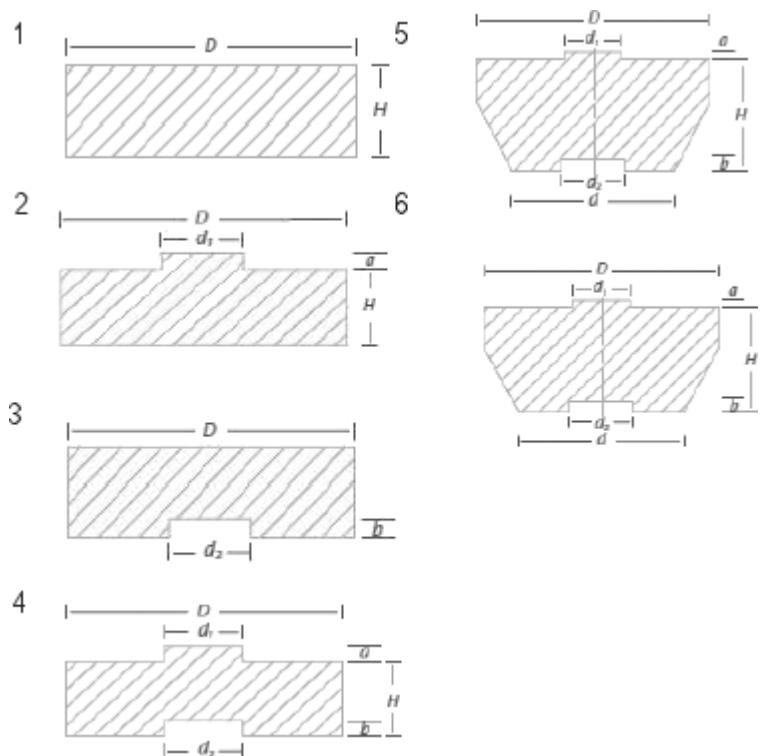

Dimensioni standard del tassello circolare (ZA): 10x85 (axd1 in mm)

Ulteriori dimensioni da eseguire a richiesta (anche su forme coniche)

PRECAUZIONI NELL'UTILIZZO DEI CROGIOLI

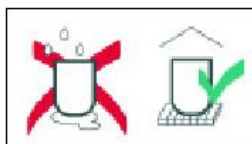

Immagazzinare i crogioli non direttamente sul pavimento in un luogo asciutto e temperato



Non impilare i crogioli uno dentro all'altro. Separarli con assi rigide



Non far rotolare i crogioli. Spostarli con l'ausilio di un carrellino



Controllare accuratamente l'integrità dei crogioli prima del loro utilizzo



Utilizzare il supporto corretto il quale deve essere posizionato centralmente per sostenere l'intera base



Lasciare lo spazio per l'espansione tra il crogiolo e flangia dell'anello superiore



Nei forni rovesciabili usare mattoni di ancoraggio correttamente posizionati, lasciando spazi per l'espansione. Non appendere il crogiolo sul bocchello



Il percorso della fiamma del bruciatore deve essere tangenziale alla superficie esterna del crogiolo



I lingotti devono essere caricati con cura all'interno del crogiolo utilizzando opportune pinze



Caricare prima boccame leggero, come ammortizzatore, e poi aggiungere verticalmente i lingotti



Aggiungere flussi solo dopo che il metallo è fuso



Evitare l'ingresso di aria fredda assicurandosi che la bocchetta di drenaggio sia ben chiusa



Le pinze per l'estrazione devono stringere il crogiolo uniformemente su entrambi i lati ad un terzo inferiore della sua altezza



Il crogiolo deve essere svuotato prima di spegnere il forno

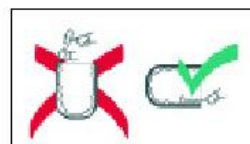

Il crogiolo dovrebbe essere pulito con cura ogni giorno quando è ancora rosso rovente